

Composite Constant Force Post

Latchways Constant Force® post is a versatile anchorage capable of providing fall protection either as fall arrest or as fall restraint. The post is simply top-fixed to the roof sheet with stitching screws thus maintaining roof integrity and not affecting the roof's compliance with Part L of the Building Regulations.

Whether used singularly as a **Single Point Anchor** or in multiples as part of a Latchways Horizontal **ManSafe®** system, the Constant Force post will comply with the recommendations of **BS EN 795: 'Protection Against Falls From A Height – Anchorage Devices – Requirements And Testing'**.

Latchways ManSafe is a horizontal cable based fall protection system that follows the contours of the roof, accommodating variable bends and slopes of up to 15°, to provide continuous protection throughout its length. For slopes greater than 15° Latchways ClimbLatch® can be used.

The range of ManSafe travelling devices, the Transfastener™, further increase design versatility by permitting the designer the opportunity to choose pre-determined entry/exit points or, for more skilled users, entry/exit anywhere along the system's length.

Correct and efficient use of Constant Force posts will require a user to wear site specific **Personal Protective Equipment (PPE)** and to be competently trained.

System design is critical and must take into consideration competency of use, intensity of access, and fall clearance. For further information please refer to the HCL **'Specifiers Guide To Fall Protection'** or contact HCL on 0800 212 867.

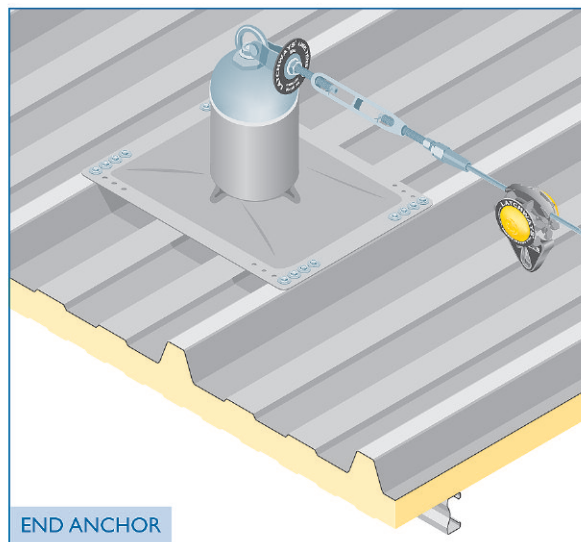

END ANCHOR

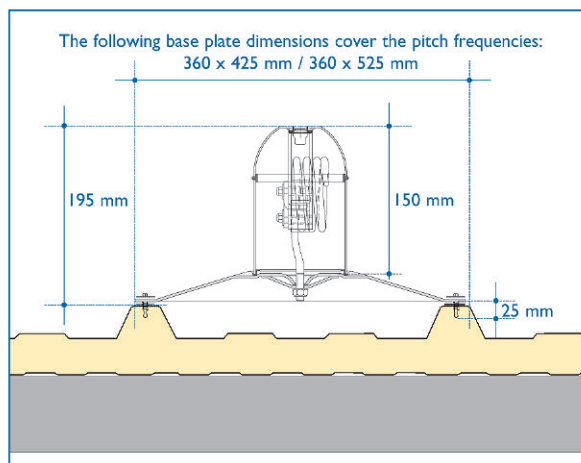

ROOF COMPATIBILITY

Uniquely, the Constant Force post is approved for use by the following roof system manufacturers: Corus Panels and Profiles, Haironville TAC, Kingspan and Ward.

MAINTENANCE

To satisfy the requirements of the Provision and Use of Work Equipment Regulations (PUWER) 1998 it is essential that Constant Force posts, whether as Single Point Anchors or as part of a ManSafe system, are inspected and maintained a minimum of once every 12 months by HCL or an HCL approved agent. This essential maintenance not only ensures that the user remains fully protected as intended but it ultimately prolongs the life of the system.

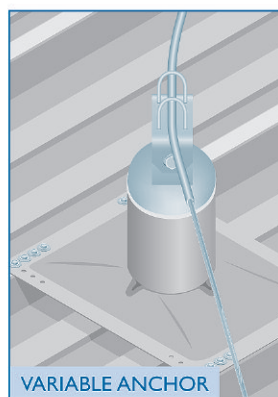

VARIABLE ANCHOR

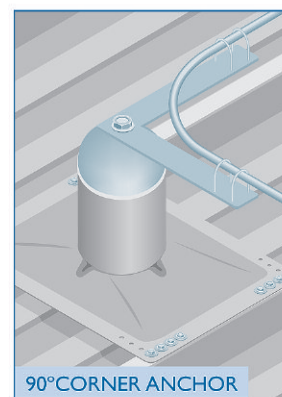

90° CORNER ANCHOR

For more information contact HCL Safety on 0800 212867